



Contribution of 3D printing in tooling and portable tools

Application case for a Smart Driller

Sylvain da Costa
Sylvain Guérin

Abstract

The recent contribution rise in 3D printing is rapidly changing the whole industry.

In aeronautics, it has 2 major domains of growth:

- Aircraft parts
- Tooling and portable tools

Aircraft parts in metallic 3D printing have been highly publicized in the media, although they represent only a tiny share of the aircraft cell in the short term.

On the other hand, metallic (and non-metallic) 3D printing in tooling and tools can bring immediate advantages compared to traditional methods.

The advantages:

- Design made directly for the final function
- Optimized for strength vs weight
- Weight reduction
- Reduction in number of parts
- Short cycle time from design to use
- Low cost for customization

The drawbacks

- Limited in size

We have already applied this new manufacturing technique to obtain real breakthroughs in portable tools.

The first and best illustration is our SD2000 Smart drill which has been completely redesigned around 3D printing:

This Smart portable drill is fully electrical with embedded 2-axis numerical control. It has a power of 2 kW for a total weight of 2.2 kg and only 4 structural parts, including a customized nose piece. Such result is impossible to achieve without the 3D printing technology.

The main body of the SD2000 is a single piece of 3D printed titanium that includes the housing of the spindle, the reference setting, the translation guidance, the feed mechanism, the thermal dissipation surfaces and the chips evacuation circuit. It is capable to apply forces up to 4kN and weighs only 500g!

The nose piece can be customized to accommodate for accessibility inside an aeronautic structure; producing different nose pieces with different shapes doesn't cost more.

Other portable tools (fastener delivery systems, screwing devices, ...) have been designed, or are currently being designed using all advantages of the 3D printing technology, and bringing to the end user new functionalities, better accessibilities and optimized ergonomics at equivalent or even lower costs.

Introduction

Tools and tooling are essential parts of the aircraft manufacturing industry and the manufacturing industry in general. However, the emergence of a truly globalized economy is pushing manufacturers all over the world to the limits of productivity. This is ultimately forcing companies to be smart and innovative in their approaches.

This paper presents some real-life samples of how metal 3D printing can contribute to enhancing productivity through an innovative tools and tooling approach. The examples also illustrate how current design thinking must be adapted to make most use of the benefits that 3D can bring, and more than compensate for the drawbacks of the 3D printing technology.

3D printing – advantages and drawbacks

3D printing in general, and specifically metal 3D printing, has a number of advantages but also some drawbacks when compared to classical manufacturing technologies like machining. Below the specific advantages for the titanium EBM technology:

The advantages

- **Free form:** There are much less process-related design restriction compared to classical manufacturing technologies.
 - It allows to add design positive complexity without added cost
 - It allows to reduce the number of parts by combining several parts together
 - It allows to achieve the best weight/stiffness ratio
- **Near net shape:**
 - Almost no post-process machining needed
 - No material waste
- **No specific tooling needed for manufacturing**
- **Stress free parts straight from the printer**
 - This characteristic is specific to EBM which does not induce heat deformation and doesn't need any heat treatment for stress relieving
- **Short cycle time**
 - Although process is relatively slow, a turnaround time of a few days is attainable
- **Low cost for customization or frequent iteration**

The drawbacks

- **Parts limited in size**
 - The EBM machine limits the size to 350mm in diameter X 380mm in height
 - However, dimensions are increasing slowly
- **Slow process**
 - It is however partially compensated by the Near net shape directly obtained
- **Surface roughness**
 - Might request some finishing either for reasons of fatigue or for visual effects

A framework of 3D manufacturing for tools and tooling

Below are some guidelines to develop a solid application case for tools and tooling manufactured with the aid of (metal) 3D printing.²

Look for tools or tooling equipment that are currently compromised

Typical candidate application areas are to be found where current tooling and tools are compromised by complexity, size, weight, lack of flexibility or ergonomics, and where the resolution of this compromise brings along a chain of positive effects on the surrounding systems or environment.

Think about weight reduction in a highly dynamic piece of equipment (which could lead to overall equipment size reduction and reduced capital expense), enhanced flexibility in a bottleneck production area, reduction of setup or assembly times, reduction of tooling maintenance or failure modes, reduction of tool changes, simplified tooling with reduced tooling lead-time etc.

Think function first

Functions and requirements of the system are driven by the surrounding systems. In case of tooling, surrounding systems could e.g. be the machine, the part to be processed etc. Starting from the current or intended application, all useful functions must be extracted.

Make sure you are complete in extracting the functions. Often a combination of functions is required in tools and tooling, e.g. a holding function, a cooling function, a moving function, even esthetics...

Combine functions and complexity into a new (re-)design for 3D printing

With 3D printing, manufacturing complexity is basically free. In case of an existing design that is being reviewed, try to identify other functionalities of surrounding components that could be integrated into the design. These added functionalities will come at near-zero cost. In an ideal case, functions of a complex assembly of multiple separate components can be combined into one 3D printed component.

Once the initial design contains all desired functionalities, the design can be topologically optimized to further reduce material use and hence cost, weight and printing time

Minimize over-engineering and post-processing

For certain features of the tooling, precision or smooth surfaces are required. However, ensure yourself that either this precision is really required or can it be compensated for, or that these features are minimized. Also consider a facilitated execution of this post-processing (machining, drilling, polishing...) in the design of a newly designed 3D printed tooling or component.

Example 1: Structural design

Functional specifications

The purpose of this example is to illustrate how Titanium Additive Manufacturing may improve the efficiency of structural parts.

The original specification of the part was to hold 4 devices with a specific position and orientation on an existing support. The part is therefore an interface between the devices and the support. Its main functions are:

- To hold the devices
- To orient the devices
- To hold electronics and cables
- To conduct heat
- To absorb shocks
- To protect the devices

With additional characteristics:

- Light weight
- High rigidity (vibration resistance)
- Heat transfer and heat resistance
- Small quantity to produce.

The original design was based on a milled aluminum plate located on the support and carrying 4 turned aluminum parts each of them holding one device, as well as 4 pockets for electronics.

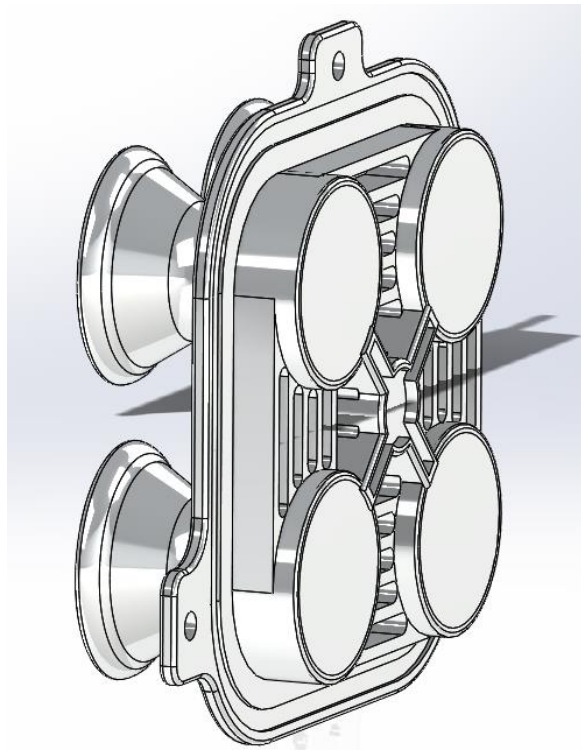

Combine functions and complexity

The part was re-engineered to fulfill all functions within a single part. The start of the re-design was the optimization of stress and load transfer lines. The volume of titanium was adjusted in order to get the required rigidity. Then, additional surfaces were placed to dissipate the heat as required, which also participated in increasing the rigidity. This is an illustration of combining mechanical and other functions into one feature of the design.

The result

On this specific structural part, the reengineering permits to save 60% of the original weight with a significant improvement in terms of rigidity. It also eliminates a delicate assembly operation.



Example 2: Functional re-design

Specifications

The purpose of this example is to illustrate how the designer can integrate several functions in a single part thanks to Titanium Additive Manufacturing.

The original specification of the component was to manipulate printed labels by a robot. To perform the cycle, several functions and characteristics have to be integrated. The main functions of the component are:

- Receive the label
- Hold the label (by means of vacuum)
- Release the label (by mean of air pressure)
- Check label presence/position (by mean of sensors)
- Press the label in place

Because this label application is robot mounted, it must also fulfill following characteristics:

- Lightweight
- High rigidity

The original design was based on a milled PEHD plate with a number of inserts. The vacuum and pressurized piping were only partially integrated in the plate by a milling operation.

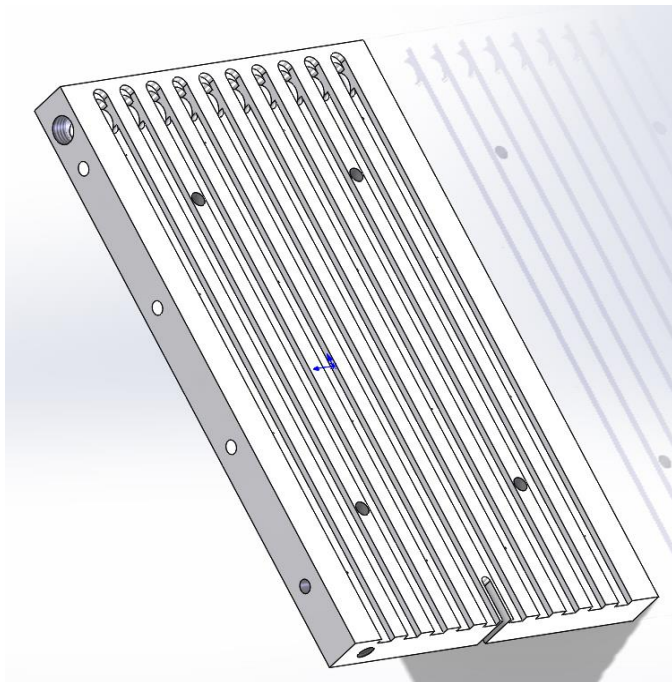

Combine functions and complexity

The part was re-engineered to fulfill the specifications and to integrate more functions in the same part. First, the design took care of the mechanical main function (volume and interface with both label and support). Then, the piping (vacuum line and pressure line) was defined and integrated in the part. Finally, the location and interface with the sensors were added. The volume of

October 2016

titanium was adjusted in order to comply with the desired resistance and rigidity.

The result

On this specific part, the re-engineering permits to save 40% of the weight with a significant improvement in terms of rigidity. The weight reduction improves the dynamics of the robot, thus

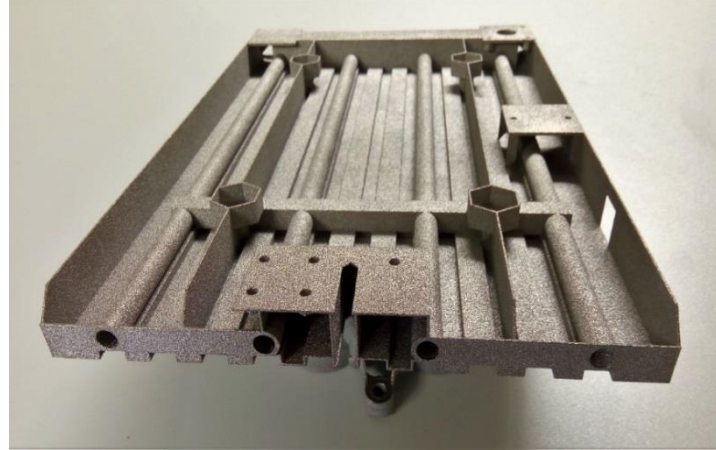

improving the cycle time. The integration of piping within the part permits to reduce the number of articles in the assembly and to reduce the assembly time, but also reduces the risk of breakdown due to fragile piping with several weak spots

Last but not least, going from PEHD to titanium drastically improves the lifetime of the component, reducing cost and equipment downtime

Example 3: Design for customization

Specifications

The purpose of this example is to illustrate how Additive Manufacturing may facilitate the customization of a product.

The product is dedicated to the mechanical surface activation of fastener heads in the aircraft industry. After installation of the fastener and before painting, the rivets must be cleaned and the excess coating which is necessary for installation has to be removed. The validated process to clean and activate the surface is friction with an abrasive material.

First, functional specification of the product were established:

- To take care of the numerous sizes and shapes of fasteners
- To maintain the abrasive material in place
- To create a pressure over the abrasive during the operation
- To transfer a relative movement between the abrasive and the fastener
- To keep dust inside the tool
- To be easily exchangeable
- To be produced at a low price, even in significant quantities

Combine function and diversity

After preliminary tests it was decided to design the prototypes by using Additive Manufacturing of polyamide material. This material had the advantage to be soft enough to avoid damaging the surface in case of failure, and strong enough for functional mechanical assembly of the tool. The idea at that point was to validate the product without the cost of a specific injection mold.

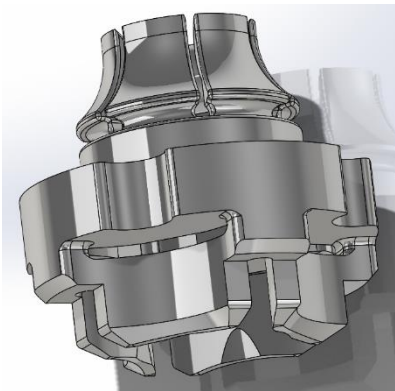

Several prototypes were designed to fulfill the specifications, and the result was a product made from 4 parts (2 AM polyamide parts,

and 2 abrasive textiles); the polyamide parts require controlled elastic deformation, so their geometry is quite complex.

The design rules to adapt the design to the numerous fasteners were determined and it was possible to achieve the activation performance for any fastener size.

Production

The final design was tested with printed polyamide parts with very good results. We investigated the option to produce the part by injection molding, but the complexity of the parts would require very sophisticated and expensive molds. Given the production quantities per unit, 3D printing was chosen as the manufacturing technology for these assemblies.



The result

For the full range of those customized parts, the use of polyamide 3D printing permits to achieve the technical performance of the products within:

- A very short engineering and validation phase
- A very cost effective qualification phase
- A serial cost lower than what is possible in injection molding.

Application case for a Smart Driller

The specifications

The idea was to develop a handheld Smart Driller to fill the gap between the pneumatic handheld drilling machines currently in production, and the very sophisticated drilling machines available on high-end automatic machines.

To go from the idea to a product, a very demanding list of requirements was established, combining the state of the art functions of the automatic drillers with the ergonomic requirements typical for handheld tools .

To list some of them:

- Electrical power for both rotation and feed
- Low voltage power for safety reasons
- Feed and rotation speed managed separately to allow any combination
- Programming capacity for each type of hole
- Speed rotation: 0 to 8000 rpm or more
- Feed from 0.001 mm/rev to 6m/mn.
- High Quality of holes and countersinking
- Possibilities of changing all parameters according to the thickness, during drilling
- Possibility to set parameters based on thrust forces and torque
- Detection of change of materials
- System to detect cutting tool exit during drilling
- Possibility to set peck parameters
- Vibrating drilling capabilities
- Imbedded lubrication
- Minimizing the weight of the machine (very important for overall ergonomic)
- NC fully integrated
- Real time quality monitoring for quality insurance
- Etc.

The list of requirements was challenging and involved a number of technological breakthroughs:

- High efficiency motors
- Embedded electronics and computer power
- Robust and accurate mechanics

The mechanical design

Apart from motors and electronics, designing and producing the mechanical parts had its own challenging requests. The machine has to be:

- Stiff in order to achieve the quality of the drilling, and the efficiency of the sensing
- Accurate in order to achieve requested bore quality
- Capable to receive numerous functions
- Customizable for customer environment
- Light enough to be easily manipulated by the worker
- Simple to assemble
- Cost effective

After investigating different materials and manufacturing technologies, the choice was oriented towards metal 3D printing in titanium.

The reason for choosing titanium was its very interesting ratio between strength and weight, as well as its natural corrosion resistance. Its main drawbacks are the difficulty of machining it with conventional methods, and the rather high cost of material.

By using 3D printing, it is possible to compensate for these drawbacks: only the necessary amount of material is printed, reducing both traditional machining cost and material cost.

Now, let's discuss the design optimization thanks to 3D printing design.

Think function first

The main body of the SD2000 is a single piece of 3D printed titanium that includes the following main functions:

- Hold spindle
- Set reference
- Translate spindle
- Hold feed mechanism
- Evacuate chips
- Hold electronics
- Cool electronics
- Participates to operator handling

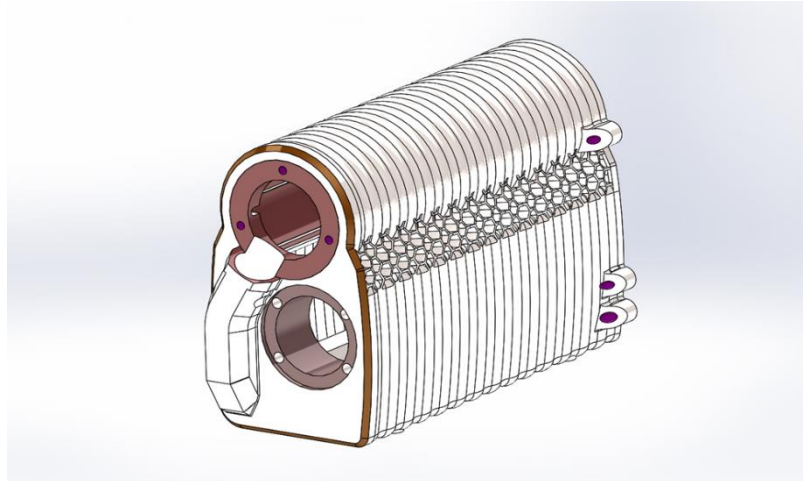

This body is capable to apply forces up to 4kN (900lbs), and weights only 500g.

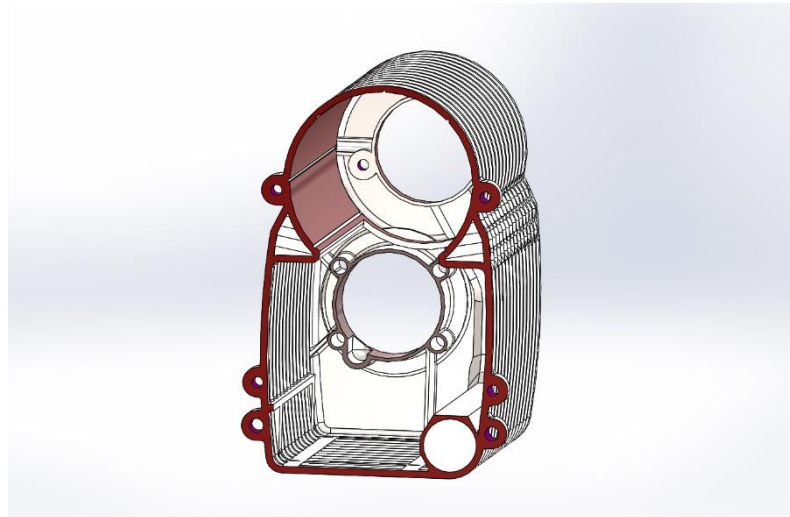

Optimization

When all performed is

-
-
-
-
-

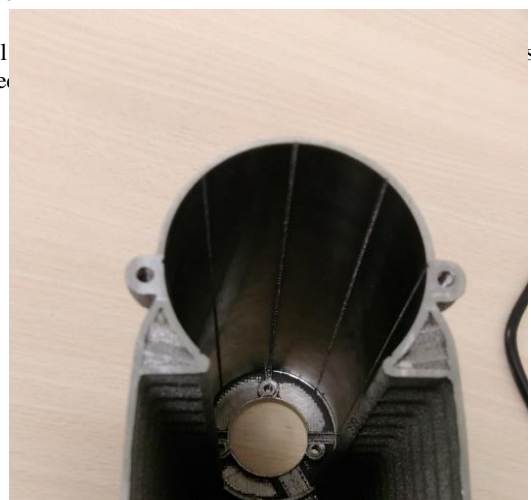

A total of 4 titanium printed parts and one plastic printed part make 90% of the structural weight.

Again, functionalities are combined; e.g.

- The ribbed surface of the tool body gives added structural stiffness as well as creating an ergonomical grip.
- The chips evacuation channel also draws cool air into the tool, aiding heat evacuation for the electronics cooling

Customization

Customization for tools and tooling is essential, as we need to adapt to a variety of shapes and accessibilities.

There again, additive manufacturing is an advantage, as single element production is nearly as efficient as series production.

For our Smart Driller, the place where customization makes the most sense is the nose piece.

The nose piece geometry depends on hole size, type of attachment (quarter rotation, concentric collet...), accessibility,... A quick selection of needed parameters, and the right nose piece is ready for manufacturing.

Another example is customizing the Smart Driller for mounting on a robot arm.



The production

EBM technology was chosen for the Additive manufacturing of titanium, and more specifically the ARCAM Q20 machine for its size capability. The size of the machine allows for series production of tools.

The EBM technology allows to print the parts and use them straight from the machine without heat treatment

The post processing of the parts consists in removing the powder and a few light supports. Only those areas of the parts will be machined where high accuracy is needed.

As an example, on the SD2000 body, only 5% of material is removed.

The production of the printed parts are made in batches, as seen in the following pictures:

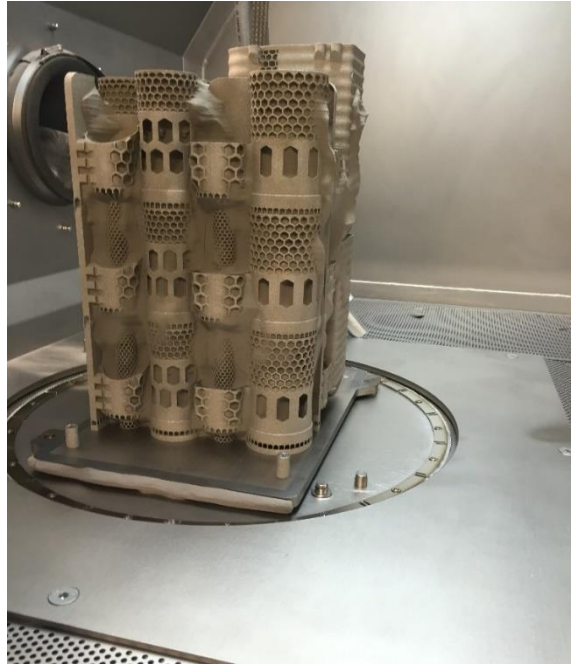

The result

The line of smart drillers has been designed specifically for titanium additive manufacturing in serial production. It is currently a family of 4 different models ranging from 200W to 3kW and weighing 600 g to 4.2 kg.

They are the most advanced hand held tools available on the market today, at competitive pricing thanks in good part to the advantage of optimization for the titanium 3D printing technology.



Conclusion

The different examples shown above and experimented by AET, illustrate how manufacturing plants can use the 3D printing manufacturing process to be innovative in term of tools and tooling. Although it requires a profound change in the way in thinking, this new technique allows to design more elaborate and more efficient objects.

And more than ever our imagination is the real limit to application of 3D printing technologies for tools and tooling.